

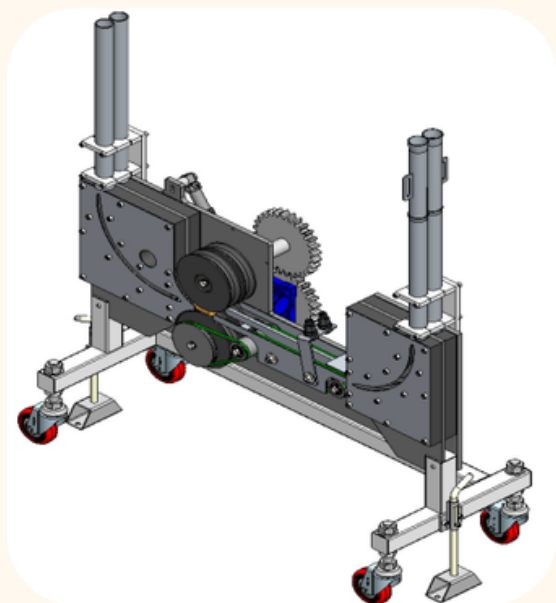

REM12-02

Continuous oriented cap transfer for marking machines



PRODUCTION

10000 - 20000 corks/h

INFEED

Configurable vertical tube

OUTFEED

Vertical tube

ACCESSORIES

Instruction manuals, CE marking plate, declaration of conformity

CORK TYPE

23 mm a 26 mm de diameter

MACHINE DIMENSIONS

850x400x1000 mm